

# Will it fit?

## Your furniture measuring guide

Please use this document as a guide to help measure your space and ensure your new furniture will fit seamlessly into your home. This includes the journey from our delivery van, through your property, and into place.

---

### PLEASE NOTE

**If you've measured up and it looks like your chosen item(s) won't fit, there may be wiggle room.**

Our experienced delivery crews will always try to come up with a solution, but it's best to know of any potential challenges upfront. Please get in touch and we can look into this further for you.

Some customers choose to remove windows, doors or radiators to get their perfect product in its rightful place, so it may be worth thinking about this in advance.

Since some of our items don't arrive fully assembled, the final dimensions you see online might not be exactly what you need to check access.

For example:

- Some sofas are delivered in two parts
- Some sofas are delivered without feet attached
- Some dining tables and sideboards are delivered without tops attached

Dimensions also do not account for packaging, so if measurements are tight then we may be able to deliver your furniture unboxed. If you have any doubts at all, please don't hesitate to contact us.

---

### MEASURING UP

The best way to ensure a smooth journey is to walk the route that your furniture will take, and note down the measurements of any potential problem points. You can then compare these to the dimensions of your furniture to see if there's enough room to fit it through.

Your furniture dimensions:

Height

Width

Depth

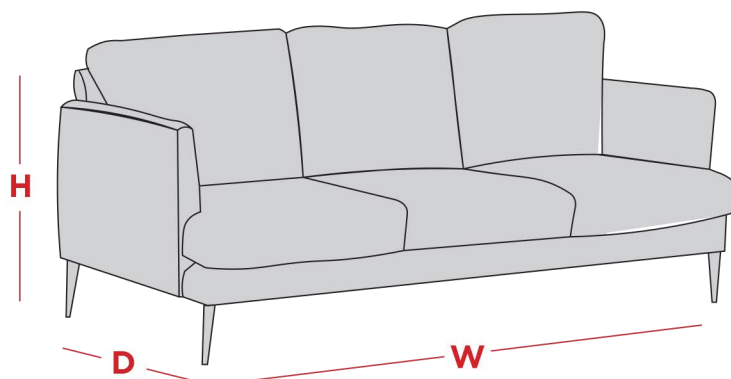

*\*Please note that the sofa image throughout this guide is just for illustration purposes only.  
This guide can be used for any piece of furniture.*

**BARKER AND  
STONEHOUSE**

## WILL IT FIT THROUGH THE DOOR?

Our skilled delivery teams often have a couple of tricks up their sleeves for navigating furniture through doorways. So if one measurement seems tight, we may be able to try another method.

### 1. Sideways

To see if your furniture will fit through the door sideways, here's what to check:

#### Door width vs furniture depth (or height)

Measure the **width** of your doorway. If this is greater than the **depth** or **height** of your furniture, it should fit through if there's enough clearance inside.

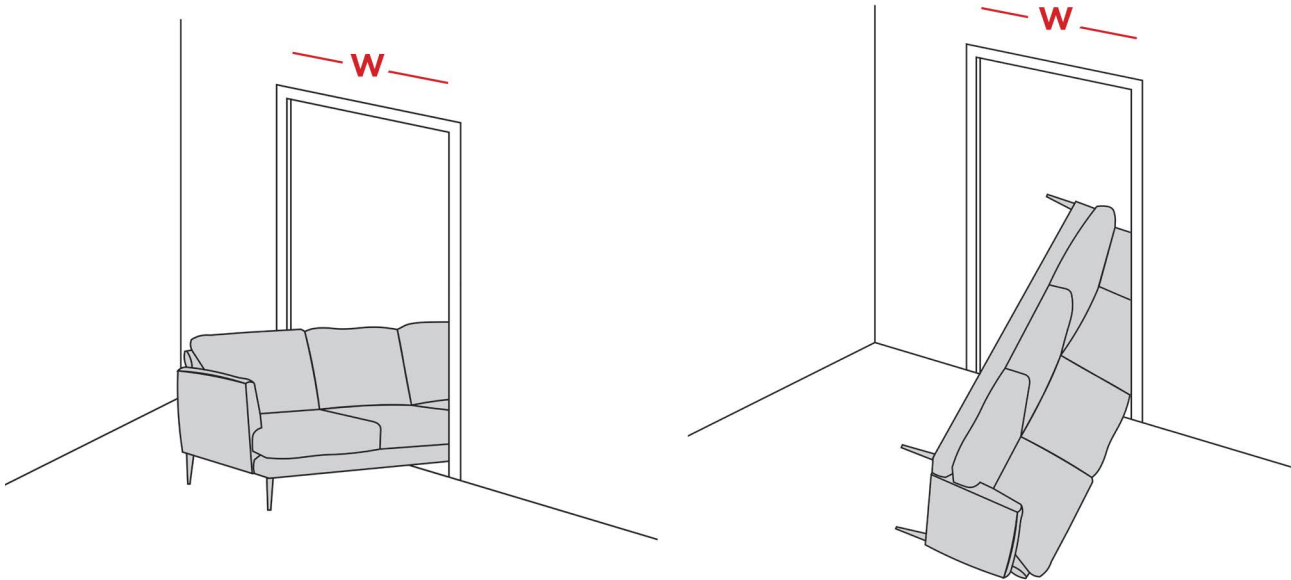

### 2. Upright

If we'll need to carry your furniture through upright, here's what to check:

#### Door height vs furniture width

Measure the **height** of your doorway from the floor to the top of the frame. If this is greater than the **width** of your furniture then we should be able to guide it through, providing that the shape of your furniture allows.

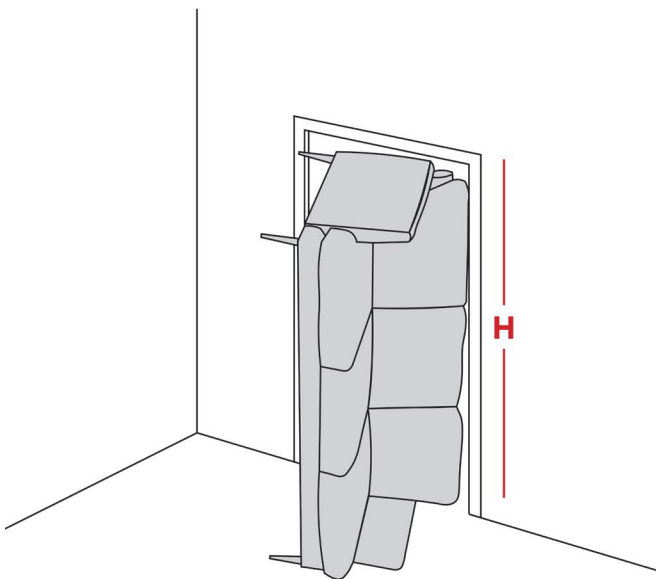

#### TOP TIPS:

- Consider any obstructions that may prevent doors from opening fully, such as radiators or door handles.
- If you need a few extra centimetres, you may wish to take the door off its hinges.
- Allow for some wiggle room - ideally 5-10cm - to make sure our delivery crew can safely manoeuvre the item through without damaging anything.
- Don't forget to measure the space on the other side of the door, to ensure there's enough space to turn or reposition the furniture inside if necessary.
- Remember to measure any internal doorways too.

## WILL IT FIT THROUGH THE HALL

Hallways can be tricky, especially if they have narrow sections, bends or obstructions. Here's how to make sure your furniture will fit through:

### Width of the hallway:

Measure the width at its narrowest point. Compare this to the depth or height of your furniture, depending on how it will be carried through.

### Height of the hallway:

Measure the height of the hallway to make sure there are no low-hanging light fixtures, beams or other ceiling obstructions that will get in the way. Compare this to the width of your furniture to see if it will fit through upright.

### Corners or bends:

If your hallway has a corner or bend, you'll need to measure the distance to the corner as well as the width around the bend. Compare these measurements to the length of your furniture to see if it can make the turn.

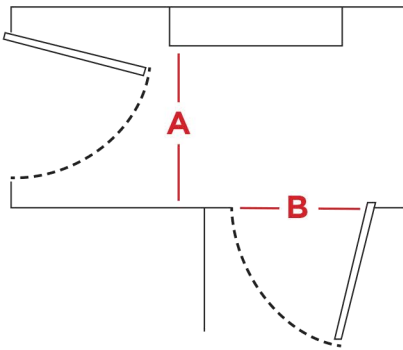

### TOP TIPS:

- Remember to factor any obstructions into your measurements, such as door frames, radiators or wall lights.
- If the furniture needs to be carried upright, or turned at any point, you'll need an extra 5-10cm to give our delivery crew room to manoeuvre.

## WILL IT FIT UP THE STAIRS?

If your furniture needs to go upstairs, try to visualise how it will need to rotate to clear any corners. Here's how to make sure it will pass through.

### Stair width:

Measure the **width** of your stairs at their narrowest point. Compare this measurement to the **smallest dimension** of your furniture (for a sofa this would usually be the depth or height, but for a tall cabinet this could be the width).

### Ceiling height:

Measure the **height** from the stairs to the ceiling at both the bottom and top of the flight, as well as any landings. Compare the **diagonal height** of the furniture to this ceiling height to check if it will clear the space.

### Landings:

Landings are the areas where the staircase changes direction or where there's a platform between flights.

- Measure the **width** of the landing and compare it to the **smallest dimension** of your furniture. You'll need this space to manoeuvre the furniture around the corner.
- Measure the **depth** of the landing and compare it to the **length** of your furniture. Make sure there's enough depth for the piece to pivot around the turn.

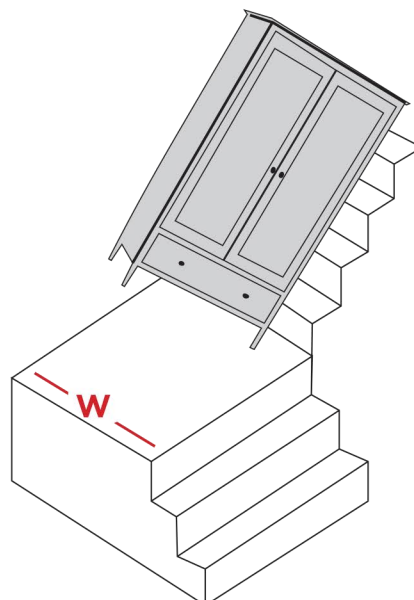

**BARKER AND  
STONEHOUSE**

## WILL IT FIT IN THE LIFT?

If your property has a lift, here's how to check that your furniture will fit inside comfortably.

### Lift door:

Measure the **width** and **height** of the lift doors. Compare these measurements to the **depth** or **width** of your furniture, depending on how it will be carried in. Ideally, there'll be some room to spare.

### Lift interior:

Measure the **depth, width** and **height** of the lift's interior. Compare these to the **depth, width** and **height** of your furniture to ensure it will fit without scraping the walls or ceiling.

#### TOP TIP:

- Check if your lift has any weight restrictions, and let us know if this might be a problem.

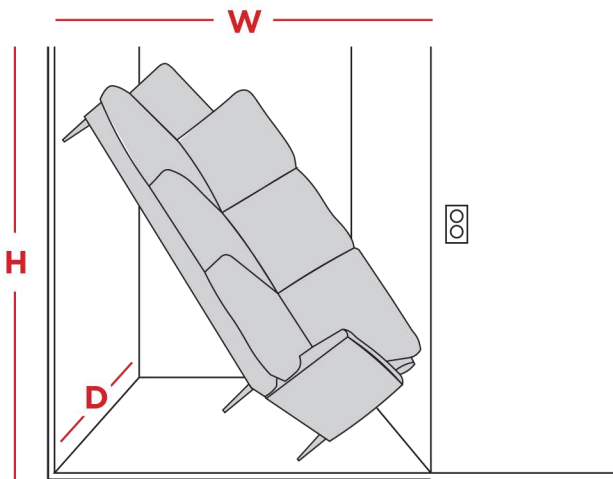

## WILL IT FIT IN YOUR ROOM OF CHOICE?

While it's important to ensure your furniture can be delivered into your home and to your chosen room, it's equally essential to make sure it fits comfortably in the space.

A great way to visualize this is by mapping out the area with any existing furniture in mind. You can use masking tape, newspaper, or similar items to mark out how much space the new piece will take up. Then, you can determine if there's enough space, say, to walk around the furniture, or to avoid it from feeling overcluttered.

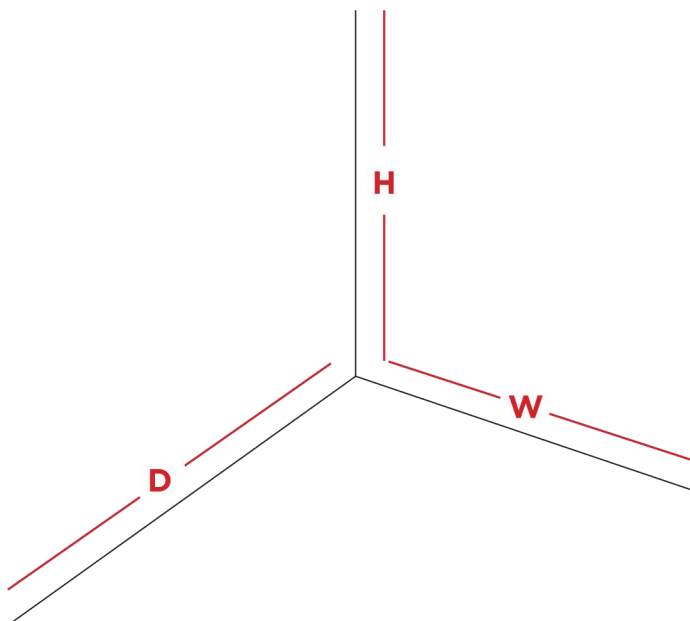

## KEY CONSIDERATIONS

We want you to enjoy your new purchase to the fullest, so be sure to consider the little details that could affect its placement in your home.

### Fixtures

Check that your furniture won't obstruct light switches, plug sockets, fireplaces, etc.

### Functional Features

Check there's enough room to use your furniture properly. Like opening drawers and doors, and operating reclining seats. If your recliner needs power, ensure that a plug socket is within easy reach. Similarly, consider the placement of large wall units and wardrobes, as they can be difficult to move once set up and may block access to outlets.

### Seat Heights

For dining chairs, ensure the seat height suits your table (typically around 76cm high) and check that the chairs fit comfortably between the table legs, allowing enough room for seating and dining comfortably. It's important to note that counter stools and bar stools vary in height - counter stools are shorter and suited to standard kitchen counters and islands, while bar stools are designed for taller tables.

### Rugs

Most of our rugs are available in multiple sizes, so please ensure that the dimensions are right for your space. This can be hard to visualise, so again we recommend that you map this out with furniture in place to confirm that you're happy with how it looks.

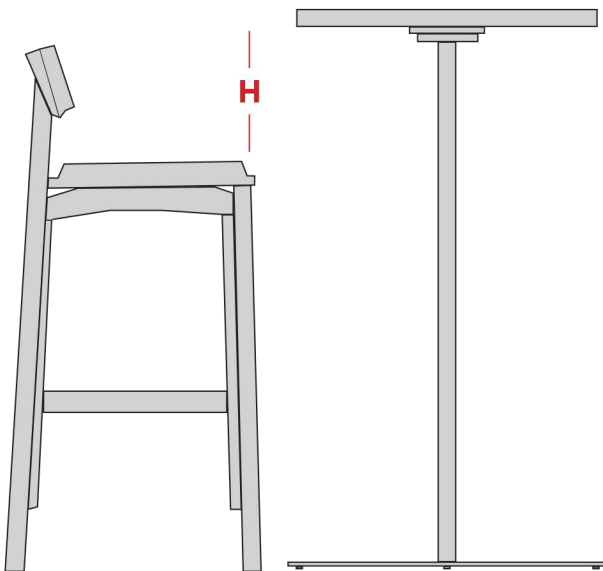

### NEED HELP?

If you have any questions, please don't hesitate to contact our friendly customer service team on **0333 010 2352**, or speak to your local store.